

Portable Air Conditioner

User Manual

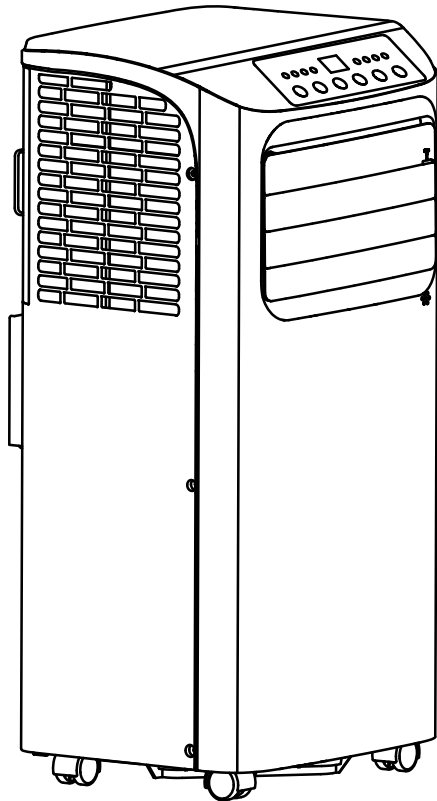

Thank you for selecting our quality appliance. Please be sure to read this user manual carefully before using. Any question, please contact the professional service for help.

CONTENTS

SAFETY INFORMATION

Important safeguards -----	01-02
Electrical Safety Warning -----	03
Integrated circuit breaker -----	04
R32 Warning -----	05-06

SET UP & USE

Description -----	07
Accessories -----	07
Installation instructions -----	08
Window slider kit installation -----	09
Location -----	09
Double-hung sash/ sliding casement window installation -----	10
Control panel -----	11
Turning the appliance on -----	11-13
Self-diagnosis -----	14
Remote control -----	15-18
Tips for correct use -----	19-20

CLEANING & CARE

Cleaning the air filters -----	21
Start-end of season operations -----	22

TROUBLESHOOTING ----- 23

SERVICE WARNING AND REQUIREMENTS ----- 24-27

IMPORTANT SAFEGUARDS

- This appliance is for household use only.
- Disconnect the appliance from its power source during service and when replacing parts and cleaning.

- Please note: Check the nameplate for the type of refrigerant gas used in your appliance.
- Specific information regarding appliances with refrigerant gas.

The appliance is recommended not to pierce the cooling circuit of the machine. At the end of its useful life, deliver the appliance to a special waste collection centre for disposal.

GWP(Global Warming Potential): R410A: 2088, R134a: 1430, R290: 3, R32: 675.

- This hermetically sealed system contains fluoridated greenhouse gases.
- ENVIRONMENTAL INFORMATION: This unit contains fluoridated greenhouse gases covered by the Kyoto Protocol.
- Do not use this unit for functions other than those described in this instruction manual.
- Make sure the plug is plugged firmly and completely into the outlet. It can result in the risk of electric shock or fire.
- Do not plug other appliances into the same outlet, it can result in the risk of electric shock.
- Do not disassemble or modify the appliance or the power cord, it can result in the risk of electric shock or fire. All other services should be referred to a qualified technician.
- Do not place the power cord or appliance near a heater, radiator, or other heat source. It can result in the risk of electric shock or fire.
- This unit is equipped with a cord that has a earthed wire connected to an earthed pin or grounding tab. The plug must be plugged into a socket that is properly installed and earthed. Do not under any circumstances cut or remove the earthed pin or grounding tab from this plug.
- The unit should be used or store in such a way that it is protected from moisture e.g. condensation, splashed water, etc. Unplug unit immediately if this occurs.
- Always transport your appliance in a vertical position and place on a stable, level surface during use. If the unit is transported laying on its side it should be stood up and left unplugged for 6 hours.
- Always use the switch on the control panel or remote controller to turn the unit off, and do not start or stop operation by plugging in or unplugging the power cord. It can result in the risk of electric shock.
- Do not touch the buttons on the control panel with your wet and damp fingers.
- Do not use hazardous chemicals to clean or come into contact with the unit. To prevent damage to the surface finish, use only a soft cloth to clean the appliance. Do not use wax, thinner, or a strong detergent. Do not use the unit in the presence of inflammable substance or vapour such as alcohol, insecticides, gasoline, etc.
- If the appliance is making unusual sounds or is emitting smoke or an unusual odor, unplug it immediately.
- Do not clean the unit with water. Water can enter the unit and damage the insulation, creating a shock hazard. If water enters the unit, unplug it immediately and contact Customer Service.
- Utilize two or more people to lift and install the unit.
- Always grasp the plug when plugging in or unplugging the appliance. Never unplug by pulling on the cord. It can result in the risk of electrical shock and damage.

-
- Install the appliance on a sturdy, level floor capable of supporting up to 110lbs(50kg). Installation on a weak or unlevel floor can result in the risk of property damage and personal injury.
 - If the appliance have the Wi-Fi function , the transmission power: less than 20dBm, and the radio frequency range is: 2412MHz-2472MHz.
 - This appliance is not intended for use by persons (including children)with reduced physical, sensory or mental capabilities,or lack of experience and knowledge, unless they have been given supervision or instruction concerning use of the appliance by a person responsible for their safety.
 - Children should be supervised to ensure that they do not play with the appliance.
 - If the SUPPLY CORD is damaged, it must be replaced by the manufacturer, its service agent or similarly qualified persons in order to avoid a hazard.
 - The appliance shall be installed in accordance with national wiring regulations.
- Cet appareil n'est pas destiné à être utilisé par des personnes (y compris des enfants) ayant des capacités physiques, sensorielles ou mentales réduites, ou un manque d'expérience et de connaissances, sauf si elles ont reçu une supervision ou des instructions concernant l'utilisation de l'appareil par une personne responsable de leur sécurité. Les enfants doivent être surveillés pour s'assurer qu'ils ne jouent pas avec l'appareil. Si le CORDON D'ALIMENTATION est endommagé, il doit être remplacé par le fabricant, son agent de service ou des personnes de qualification similaire afin d'éviter tout danger. L'appareil doit être installé conformément aux réglementations de câblage nationales.

SAFETY INFORMATION

DANGER

DANGER - Immediate hazards which **WILL** result in severe personal injury or death

WARNING

WARNING - Hazards or unsafe practices which **COULD** result in severe personal injury or death

CAUTION

CAUTION - Hazards or unsafe practices which **COULD** result in minor personal injury

IMPORTANT SAFETY INSTRUCTIONS

WARNING

When using electrical appliances, basic safety precautions should be followed, including the following

SAVE THESE INSTRUCTIONS

HOUSEHOLD USE ONLY

IMPORTANT - GROUNDING METHOD

This product is factory equipped with a power supply cord that has a three-pronged grounded plug. It must be plugged into a mating grounding type receptacle in accordance with the National Electrical Code and applicable local codes and ordinances. If the circuit does not have a grounding type receptacle, it is the responsibility and obligation of the customer to exchange the existing receptacle in accordance with the National Electrical Code and applicable local codes and ordinances. The third ground prong should not, under any circumstances, be cut or removed. Never use the cord, the plug or the appliance when they show any sign of damage. Do not use your appliance with an extension cord unless it has been checked and tested by a qualified electrical supplier. Improper connection of the grounding plug can result in risk of fire, electric shock and/or injury to persons associated with the appliance. Check with a qualified service representative if in doubt that the appliance is properly grounded.

ELECTRICAL CONNECTIONS

Before plugging the appliance into the mains socket, check that:

- The mains power supply corresponds to the value indicated on the rating plate on the back of the appliance.
- The power socket and electrical circuit are adequate for the appliance.
- The mains socket matches the plug. If this is not the case, have the plug replaced.
- The mains socket is adequately earthed. Failure to follow these important safety instructions absolves the manufacturer of all liability.

WARNING

Electrical Safety Warning

- Always plug into a fixed 115V AC ground outlet.
- Push the power plug all the way into the wall outlet so that it will not loosen.
- Never plug or unplug the appliance with wet hands.
- Always grip the plug firmly and pull straight out from the outlet when taking it out.
- Never unplug the appliance by pulling on the power cord.
- Never use the appliance if the outlet is damaged or loose.



- This product should be plugged directly into a power outlet. Power outlets should be properly rated, protected, and sized in order to avoid electrical overload.
- Do not use a multiple-outlet power strip or extension cord. Failure to do so may result in short-circuit or electrical shock.
- Do not use an AC plug adapter with this appliance.
- Do not cut or remove the third (ground) prong from the power cord.

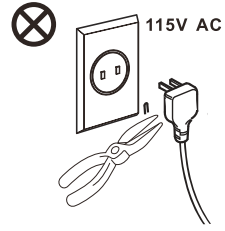
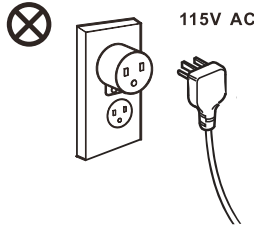
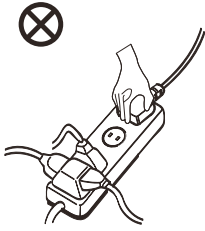

- Your air conditioner must be used in a properly grounded wall receptacle. If the wall receptacle you intend to use is not adequately grounded or not protected by a time-delay fuse or circuit breaker, have a qualified electrician install the proper wall power receptacle before using this appliance.
- Be sure that the air conditioner is properly grounded. To minimize shock and fire hazards, proper grounding is important. The power cord is equipped with a three prong grounding plug for protection against shock hazards.
- Do not cover the power cord with a rug or carpeting.
- Do not rest hot or heavy objects on the appliance and power cord.

If the power cable is damaged, it must be replaced by the manufacturer or an authorized technical service center in order to avoid all risk.

- Do not damage, alter, excessively bend, twist, pull or heat the power cord.
- Do not run the air conditioner without the white plastic shell in place. This could result in mechanical damage within the air conditioner.
- During the installing or moving the appliance, be careful not to pinch, crush, or damage the power cord.
- Always unplug the unit from the outlet before cleaning or maintenance operations.

INTEGRATED CIRCUIT BREAKER

For additional safety, the power cord features an integrated circuit breaker. Test and reset buttons are provided on the plug case.

The circuit breaker should be tested periodically by pressing the **TEST** button. If it does not cause the circuit breaker to trip, or if the **RESET** button will not stay engaged, unplug the appliance immediately and contact your service technician.

Note: Your appliance's power cord and plug may differ from above the picture shows.

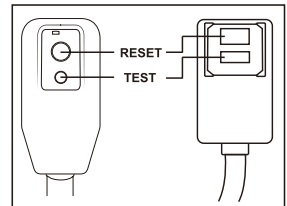

PREFERRED GROUNDING METHOD

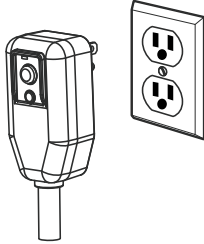

Ensure proper ground exists before use.

TEMPORARY GROUNDING METHOD

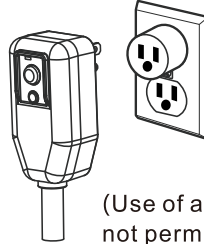

Ensure proper ground exists before use.

(Use of adapter plugs is not permitted in Canada)

RECOMMENDED GROUND METHOD

For your personal safety, this appliance must be grounded. This appliance is equipped with a 3 prong power supply cord with a grounded plug. To minimize the possibility of electrical shock, the cord must be plugged into a 3 prong outlet and grounded in accordance with all local codes and ordinances. If a 3 prong outlet is not available, it is the customer's responsibility to have a properly grounded 3 prong outlet installed by a qualified electrician. Never use a broken or damaged adapter.



DANGER - Improper connection of the equipment grounding conductor can result in a risk of electric shock. The conductor with insulation having an outer surface that is green with or without yellow stripes is the equipment grounding conductor. If repair or replacement of the Cord or plug is necessary, do not connect the equipment-grounding conductor to a live terminal. Check with a qualified electrician or service person if the grounding instructions are not completely understood, or if in doubt as to whether the appliance is properly grounded. Do not modify the plug connected to the appliance - if it will not fit the outlet, have a proper outlet installed by a qualified electrician.

WARNING

Do not use means to accelerate the defrosting process or to clean, other than those recommended by the manufacturer.

The appliance shall be stored in a room without continuously operating ignition sources (for example: open flames, an operating gas appliance or an operating electric heater).

Do not pierce or burn.

Be aware that refrigerants may not contain an odour.

The above 4 statements shall also be accompanied by the risk of fire symbol. This symbol shows a flame in a triangle (warning symbol W021 of ISO 7010).

See the following for the French version:

AVERTISSEMENT

Ne pas utiliser de produits permettant d'accélérer le dégel ou de produits de nettoyage autres que ceux recommandés par le fabricant.

L'appareil doit être entreposé dans un endroit sans source d'allumage fonctionnant en continu (par exemple : flamme nue, appareil au gaz en marche ou radiateur électrique en marche).

Ne pas percer ni brûler.

Attention : les frigorigènes peuvent être inodores.

The following information is also specified in the manual for units with flammable refrigerant (R32).

[x] the maximum refrigerant charge amount (Refer to nameplate marking refrigerant amount);

[x] information for handling, installation, cleaning, servicing and disposal of refrigerant;

[x] a warning to keep any required ventilation openings clear of obstruction;

[x] a notice that servicing shall be performed only as recommended by the manufacturer.

[x] a warning that the appliance shall be stored in a well-ventilated area where the room size corresponds to the room area as specified for operation;

[x] a warning that the appliance shall be stored in a room without continuously operating open flames (for example an operating gas appliance) and ignition sources (for example an operating electric heater).

[x] instructions as to how the appliance is to be stored so as to prevent mechanical damage from occurring.

[x] specific information about the required qualification of the working personnel for maintenance, service and repair operations.



WARNING

The handling, installation, storage, servicing and disposal must comply with the provisions of gas-related national laws and regulations, and also national wiring regulation. It is necessary to clear away the refrigerant in the system when maintaining or scrapping an appliance. Ventilated area (open doors and Windows) Ensure that the working area is open or well ventilated before turning on the system or performing hot work. Ventilation should be maintained during operation. Ventilation quickly displaces safely diluted leaked refrigerant into the atmosphere. Flammable refrigerant R32/R290 is used within appliance. Please follow the instructions carefully to handle, install, clean, and service the appliance to avoid damage or hazard. Do not dispose of appliance in regular trash. Contact qualified agency for proper disposal. Servicing shall be performed only as recommended by the manufacturer.

DESCRIPTION

1. Control panel
2. Deflector
3. Remote control receiver
4. Intake grille
5. Castors
6. Handle
7. Air outlet grille
8. Power cable
9. Intake grille
10. Condenser drain

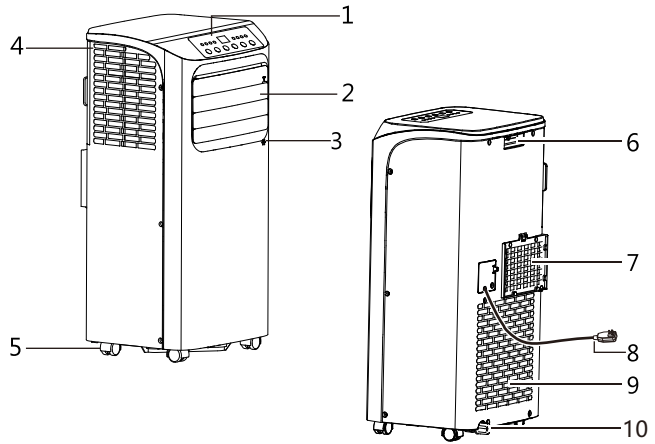

ACCESSORIES

PARTS		NAME	QUANTITY	
		Hose inlet		x 1
		Exhaust hose	1set	x 1
		Hose outlet		x 1
		Window slider without hole	1set	x 1
		Window slider with hole		x 1
		Butterfly Bolt		x 1
		Remote Control		x 1
		Battery		x 2
		Foam seal A (adhesive type) size:1000x40x4mm	1set	x 2
		Foam seal B (no adhesive type) size:1000x40x20mm		x 1
		Drainage hose		x 1

NOTE:

All the illustrations in this manual are for explanatory purposes only. Your appliance may be slightly different. Be sure all accessories are removed from the packing before use.

INSTALLATION INSTRUCTIONS

EXHAUSTING HOT AIR

When use the appliance in cool mode, the hot air exchange of the condenser must be exhausted out of the room completely.

- The exhaust duct assembly has been assembled and does not need to be connected again. Please check.(fig.1)

if you found that the connector is loose or dropped, it can be fixed and connected according to (fig. 2) and (fig. 3) .

1 .Extend either side of the hose (Fig.1), and screw the hose inlet (Fig.3).

2 .Extend the other side of the hose and screw it to the hose outlet (Fig.3).

- Install the hose inlet into the unit (Fig.4).

- Affix the hose outlet into the window slider kit and seal. (Fig.5 &6).

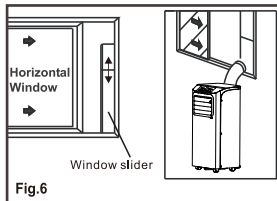
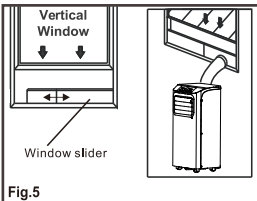
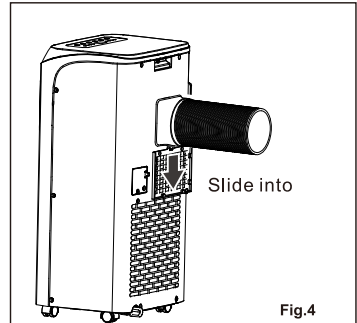
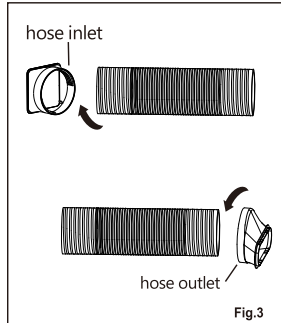
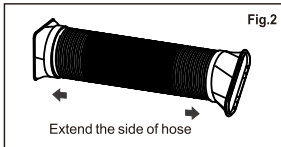
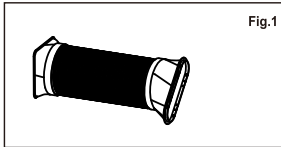

WINDOW SLIDER KIT INSTALLATION

Pull out the inner slide to match the length of the window. Align the length and assemble the fixing clip. After installing, check for no gaps in the window.

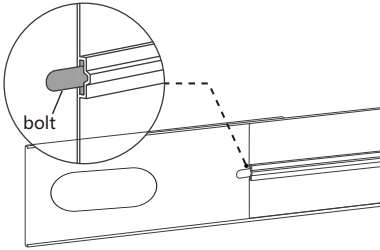

Align the back side slot with the panel's butterfly bolt.

Note: The butterfly bolt must be inserted in the backside slot before installing the panel on the window.

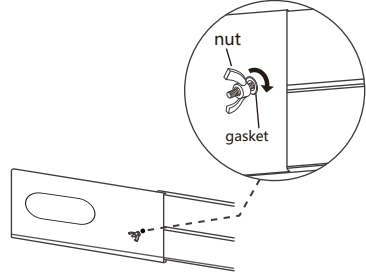

Secure the panels by tightening the butterfly bolt.

LOCATION

- The unit should be placed on a firm foundation to minimize noise and vibration. For safe and secure positioning place the unit on a smooth, level floor strong enough to support the unit.
- The unit has casters to aid placement, but it should only be rolled on smooth, flat surfaces. Use caution when rolling on carpeted surfaces. Use caution and protect floors when rolling over wood floors. Do not attempt to roll the unit over objects.
- The unit must be placed within reach of a properly rated grounded socket.
- Never place any obstacles around the air inlet or outlet of the unit.
- Allow at least 18" (45cm) of around and above space away from the wall for efficient working.
- The hose can be extended, but it is the best to keep the length to minimum required. Also make sure that the hose does not have any sharp bends or sags.

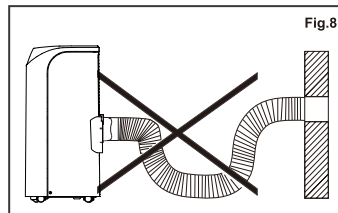
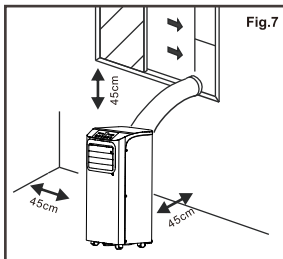

INSTALLATION INSTRUCTIONS

DOUBLE-HUNG SASH/SLIDING SASH WINDOW INSTALLTION

1. Open the window, Cut the foam seal(adhesive type) to the proper length and attach it to the window two inside. (Fig.9)
2. Attach the window slider kit to the window sash. Adjust the length of the window slider kit according to the width of window. (Fig.10)
3. Close the window securely against the window slider kit. (Fig.11)
4. Cut the foam seal(no adhesive type) to an appropriate length and seal the open gap between the top window frame and outer window frame. (Fig.12)

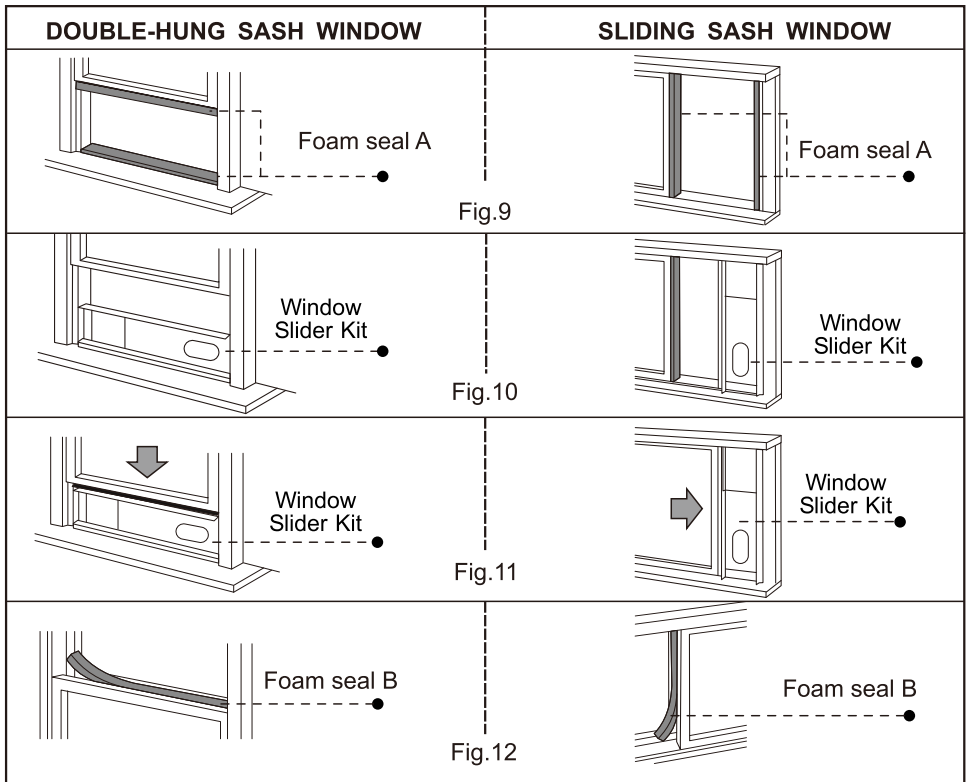

DESCRIPTION OF THE DISPLAY SCREEN AND CONTROL PANEL

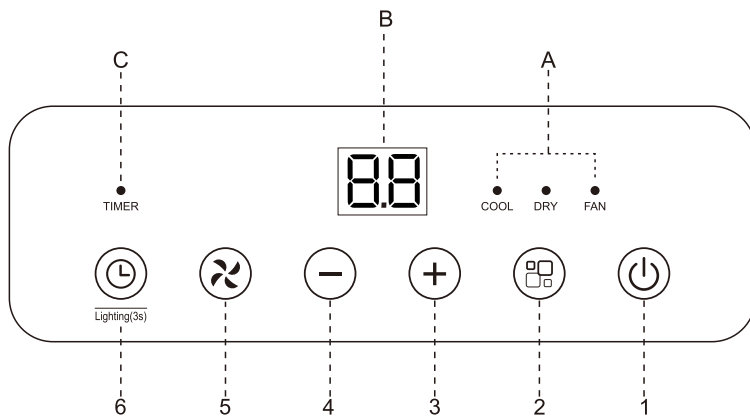

1. ON/OFF button
2. Mode button
3. Increase button
4. Decrease button
5. Fan speed button
6. Timer button

- A. Mode symbol
COOL\DRY\FAN
- B. Display screen
- C. Timer symbol

TURNING THE APPLIANCE ON

Plug into the mains socket, then the appliance is standby.



Press the  button to make the appliance turn on.

The last function active when it was turned off will appear.

COOL mode

Ideal for hot muggy weather when you need to cooling and dehumidify the room.

To set this mode correctly:

- Press the  button a number of times until the "Cool" symbol appears.
- Select the target temperature 16°C-31°C (61°F -88°F) by pressing the - or + button until the corresponding value is displayed.
- Select the required fan speed by pressing the  button.



Two speeds are available: F1(low fan speed) / F2(high fan speed).

The most suitable temperature for the room during the summer varies from 24°C to 27°C (75°F to 81°F). You are recommended, however, not to set a temperature much below the outdoor temperature. The fan speed difference is more noticeable when the appliance is under Fan mode but may not be noticeable under Cool mode.

FAN mode

When using the appliance in this mode, the air hose does not need to be attached.



- Press the "Fan" button a number of times until the "Fan" symbol appears.
- Select the required fan speed by pressing the fan speed button.

Two speeds are available: F1(low fan speed) / F2(high fan speed).

DRY mode

Ideal to reduce room humidity (spring and autumn, damp rooms rainy periods, etc). In dry mode, the appliance should be prepared in the same way as for cool mode, with the air exhaust hose attached to enable the moisture to be discharged outside.

To set this mode correctly:



- Press the "Dry" button a number of times until the Dry symbol appears.
- Select the target temperature 16°C-31°C (61°F-88°F) by pressing the - or + button until the corresponding value is displayed.
- In this mode, fan speed is selected automatically by the appliance and can not be set manually.

SWING function

Notes: This serial unit have no auto swing function

- Hold the horizontal deflectors and move up and down for comfort.
- Hold the vertical deflectors and move left or right for comfort.

A: Horizon deflector; B: Vertical deflector

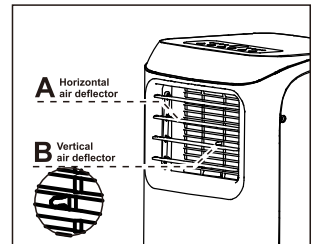

LIGHTING function

This function is applicable to sleep at night, when the machine is running, you can press and hold "TIMER" button for 3sec, all the display screen will be turned off; When pressed and hold again, all display lights will resume.

SETTING THE TIMER

-This timer can be used to delay the appliance start-up or shutdown, this avoids wasting electricity by optimizing operating periods.

* Programming start-up

- Turn on the appliance, choose the mode you want, for example Dehumidify mode, high fan speed. Turn off the appliance.

- Press the "⌚" button , the screen starts to flash, press the " - " / " + " to adjust the set time from 0.5-24 hours.

- In 5 seconds without the operation, the timer start function, then the "Timer" symbol lights.

- Press the "⌚" button again to cancel the Timer, and the "Timer" symbol disappear.

* Programming shut down

- When the appliance is running, press the "⌚" button, the screen starts to flash.

- Press the " - " / " + " to adjust the set time from 0.5-24 hours.

- In 5 seconds without the operation, the timer start function, then the " Timer" symbol lights.

- Press the "⌚" button again to cancel the Timer, and the " Timer " symbol disappear.

Switch the unit of temperature

When the appliance is running, hold on " - " / " + " button together 3 seconds by the same time, then you can change the unit of temperature.

For example:

Before change, in cool mode, the screen display like fig.9.

After change, in cool mode, the screen display like fig.10.





Fig.9



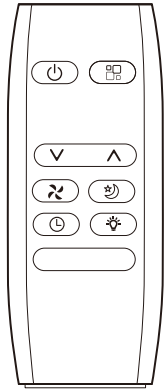







Fig.10

SELF-DIAGNOSIS

The appliance has a self diagnosis system to identify a number of malfunctions. Error messages are displayed on the appliance display.

IF IS DISPLAYED	WHAT SHOULD I DO?
 <p>PROBE FAILURE (sensor damaged)</p>	<p>If this is displayed, contact your local authorize service centre.</p>
 <p>High water level (safety tank full)</p>	<p>Empty the internal safety tank, following the instructions in the "End of season operations" paragraph.</p>

Remote Control

		On/Off button		FAN button
		Increase button		Mode button
		Decrease button		Sleep button
		Timer button		
		Display LED		

- ✓ Point the remote control at the receiver on the appliance.
- ✓ The remote control must be no more than 7 meters away from the appliance (without obstacles between the remote control and the receiver).
- ✓ The remote control must be handled with extreme care. Do not drop it or expose it to direct sunlight or sources of heat.
- ✓ If the remote control do not work, please try to take out the battery, and put it back again.

INSERTING OR REPLACING THE BATTERIES

- Remove the cover on the rear of the remote control;
- Insert two "AAA" 1.5V batteries in the correct position (see instructions inside the battery compartment);
- Put the cover back to the remote control.

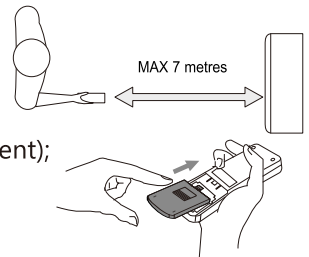



NOTE:

- ✓ If the remote control unit is replaced or disposed of, the batteries must be removed and discarded in accordance with current legislation as they are harmful to the environment.
- ✓ Do not mix old and new batteries. Do not mix alkaline, standard (carbon-zinc) or rechargeable (nickel-cadmium) batteries.
- ✓ Do not dispose of batteries in fire. Batteries may explode or leak.
- ✓ If the remote control is not be used for a certain length of time, remove the batteries.

COOL mode

Ideal for hot muggy weather when you need to cooling and dehumidify the room
To set this mode correctly:



- Press the  button a number of times until the "Cool" symbol appears.
- Select the target temperature 16°C-31°C (61°F -88°F) by pressing The + or - button until the corresponding value is displayed.
- Select the required fan speed by pressing the  button.

Two speeds are available: F1(low fan speed) / F2(high fan speed)

The most suitable temperature for the room during the summer varies from 24°C to 27°C (75°F to 81°F). You are recommended, however, not to set a temperature much below the outdoor temperature. The fan speed difference is more noticeable when the appliance is under FAN mode but may not be noticeable under COOL mode.

FAN mode

When using the appliance in this mode, the air hose does not need to be attached.

- Press the  button a number of times until the "Fan" symbol appears.
- Select the required fan speed by pressing the  button.

Two speeds are available: F1(low fan speed) / F2(high fan speed).

DRY mode

Ideal to reduce room humidity (spring and autumn, damp rooms rainy periods, etc). In dry mode, the appliance should be prepared in the same way as for cool mode, with the air exhaust hose attached to enable the moisture to be discharged outside.

To set this mode correctly:

- Press the  button a number of times until the "Dry" symbol appears.
- In this mode, fan speed is selected automatically by the appliance and can not be set manually.

SLEEP function

This function is useful for the night as it gradually reduces operation of the appliance.

To set this function correctly:

- Select the cool or heat mode as described above.
- Press the  button, and the "Sleep" symbol appears.
- When you choose the sleep function, the screen will reduce the brightness, and the fan speed is low.

The SLEEP function maintains the room at optimum temperature without excessive fluctuations in either temperature or humidity with silent operation. Fan speed is always at Low, while room temperature and humidity vary gradually to ensure the most comfortable.

When in COOL mode, the selected temperature will increase by 1°C(1°F) per hour in a 2 hour period. This new temperature will be maintained for the next 6 hours. Then the appliance turn it off.

When in HEAT mode, the selected temperature will decrease by 1°C(1°F) per hour in a 3 hour period. This new temperature will be maintained for the next 5 hours. Then the appliance turn it off.

The SLEEP function can be canceled at any time during operation by pressing the "Sleep", "Mode" or "fan speed" button.

In DRY and SMART mode, SLEEP function is still available.

SWING function

Notes: This serial unit have no auto swing function.

The swing  button operation is invalid, you can manually change the wind direction.

- Hold the horizontal deflectors and move up and down for comfort.
- Hold the vertical deflectors and move left or right for comfort.

A: Horizon deflector; B: Vertical deflector

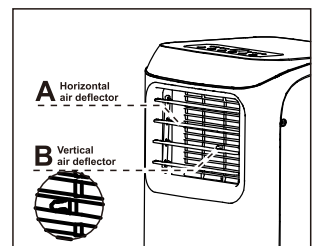

LIGHT function

This function is applicable to sleep at night, when the machine is running, you can press the "  " button, all the display screen will be turned off; When pressed again, all display lights will resume.

SETTING THE TIMER

-This timer can be used to delay the appliance start-up or shutdown, this avoids wasting electricity by optimizing operating periods.

* **Programming start-up**

- Turn on the appliance, choose the mode you want, for example Dehumidify mode, high fan speed. Turn off the appliance.

- Press the "  " button , the screen starts to flash, press the " - " / " + " to adjust the set time from 0.5-24 hours.

- Press the "  " button again to cancel the Timer, and the "Timer" symbol disappear.

* **Programming shut down**

- When the appliance is running, press the "" button, the screen starts to flash.

- Press the " - " / " + " to adjust the set time from 0.5-24 hours.

- Press the "  " button again to cancel the Timer, and the " Timer " symbol disappear.

TIPS FOR CORRECT USE

To get the best from your appliance, follow these recommendations:

- Close the windows and doors in the room to be air conditioned (fig. 14). When installing the appliance semi-permanently, you should leave a door slightly open (as little as 1 cm) to guarantee correct ventilation;
- Protect the room from direct exposure to the sun by partially closing curtains and/or blinds to make the appliance much more economical to run (fig. 15);
- Never rest objects of any kind on the appliance;
- Do not block the air inlet or outlet of the appliance. Reduced air flow will result in poor performance and could damage the unit (fig. 16).
- Make sure there are no heat sources in the room;
- Never use the appliance in very damp rooms (laundries for example).
- Never use the appliance outdoors.
- Make sure the appliance is standing on a level surface. If necessary, place the castor locks under the front wheels.

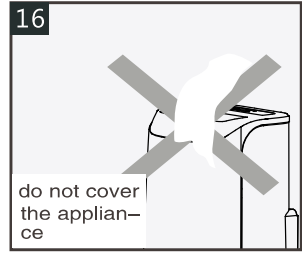
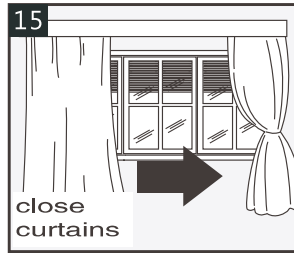
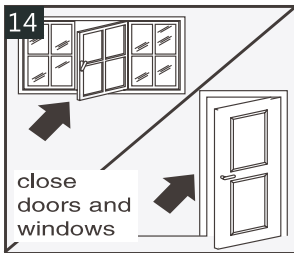

WATER DRAINAGE METHOD

When there is excess water condensation inside the unit, the appliance stops running and shows "HL" (High water level). This indicates that the water condensation needs to be drained using the following procedures:

Manual Draining (fig.17)

Water may need to be drained in high humidity areas

1. Unplug the unit from power source.
2. Place a drain pan under the lower drain plug. See diagram.
3. Remove the lower drain plug.
4. Water will drain out and collect in the drain pan (not supplied).
5. After the water is drained, replace the lower drain plug firmly.
6. Turn on the unit.

Continuous Draining (fig.18)

While using the unit in dehumidifier mode, continuous drainage is recommended.

1. Unplug the unit from the power source.
2. Remove the drain plug. While doing this operation some residual water may spill so please have a pan to collect the water.
3. Connect the drain hose (1/2" or 12.7mm, maybe not supplied). See diagram.

4. The water can be continuously drained through the hose into a floor drain or bucket.

5. Turn on the unit.

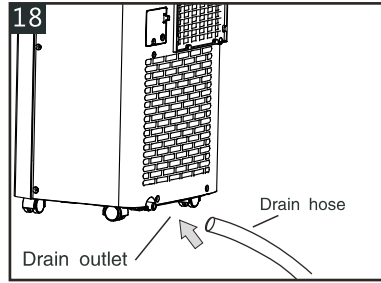
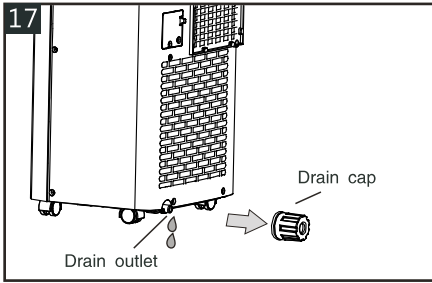

NOTE

Please be sure that the height of and section of the drain hose should not be higher than that of the drain outlet, or the water tank may not be drained.

(fig.19 and fig.20)

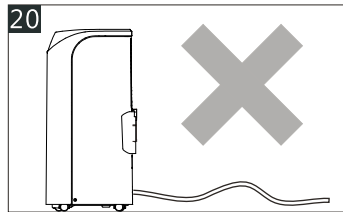
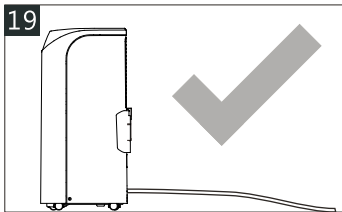

CLEANING

Before cleaning or maintenance, turn the appliance off by pressing the  button on the control panel or remote control, wait for a few minutes then unplug from the mains socket.

CLEANING THE CABINET

You should clean the appliance with a slightly damp cloth then dry with a dry cloth.

- Never wash the appliance with water. It could be dangerous.
- Never use petrol, alcohol or solvents to clean the appliance.
- Never spray insecticide liquids or similar.

CLEANING THE AIR FILTERS

To keep your appliance working efficiently, you should clean the filter every month of operation.

The filter can take out like fig.21 below.

To avoid possible cuts, avoid contacting the metal parts of the appliance when removing or reinstalling the filter. It can result in the risk of personal injury.

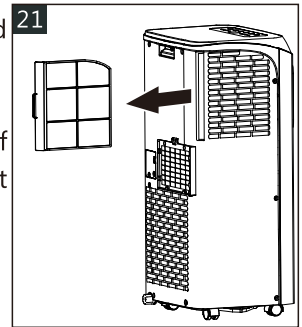

Use a vacuum cleaner to remove dust accumulations from the filter. If it is very dirty, immerse in warm water and rinse a number of times. The water should never be hotter than 40°C(104°F). After washing, leave the filter to dry then attach the intake grille to the appliance.

START-END OF SEASON OPERATIONS

START OF SEASON CHECKS

Make sure the power cable and plug are undamaged and the earth system is efficient.

Follow the installation instructions precisely.

END OF SEASON OPERATIONS

To empty the internal circuit completely of water, remove the cap.(Fig.22)

Run off all water left into a basin. When all the water has been drained, put the cap back in place.

Clean the filter and dry thoroughly before putting back.

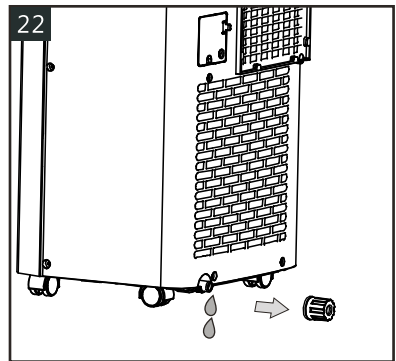

Strictest operation environment:

Cooling mode: 18°C-35°C (64°F -95°F)

Heating mode: 10°C-25°C (50°F -77°F)

TROUBLESHOOTING

PROBLEM	CAUSE	SOLUTION
The appliance does not come on	<ul style="list-style-type: none"> • There is no current • It is not plugged into the mains • The internal safety device has tripped 	<ul style="list-style-type: none"> • Wait • Plug into the mains • Wait 30 minutes, if the problem persists, contact your service center
The appliance works for a short time only	<ul style="list-style-type: none"> • Here are bends in the air exhaust hose • Something is preventing the air from being discharged 	<ul style="list-style-type: none"> • Position the air exhaust hose correctly, keeping it as short and free of curves as possible to avoid bottlenecks • Check and remove any obstacles obstructing air discharge
The appliance works, but does not cool the room	<ul style="list-style-type: none"> • Windows, doors and/or curtains open 	<ul style="list-style-type: none"> • Close doors, windows and curtains, bearing in mind the "tips for correct use" given above
	<ul style="list-style-type: none"> • There are heat sources in the room (oven, hairdryer, etc) 	<ul style="list-style-type: none"> • Eliminate the heat sources
	<ul style="list-style-type: none"> • The air exhaust hose is detached from the appliance 	<ul style="list-style-type: none"> • Fit the air exhaust hose in the housing at the back of the appliance
	<ul style="list-style-type: none"> • The technical specification of the appliance is not adequate for the room in which it is located 	<ul style="list-style-type: none"> • Move the air conditioner to a suitable room
During operation, there is an unpleasant smell in the room	<ul style="list-style-type: none"> • Air filter clogged 	<ul style="list-style-type: none"> • Clean the filter as described above
The appliance does not operate for about three minutes after restarting it	<ul style="list-style-type: none"> • The internal compressor safety device prevents the appliance from being restarted until three minutes have elapsed since it was last turned off 	<ul style="list-style-type: none"> • Wait. This delay is part of normal operation
The following message appears on the display: E2/E 1/HL	<ul style="list-style-type: none"> • The appliance has a self diagnosis system to identify a number of malfunctions 	<ul style="list-style-type: none"> • See the SELF-DIAGNOSIS Chapter

REPAIR AND MAINTENANCE SERVICE WARNING AND REQUIREMENTS

DD.3.3 Qualification of workers

The manual shall contain specific information about the required qualification of the working personnel for maintenance, service and repair operations. Every working procedure that affects safety means shall only be carried out by competent persons according to Annex HH.

Examples for such working procedures are:

- breaking into the refrigerating circuit;
- opening of sealed components;
- opening of ventilated enclosures

DD.4 Information on servicing

DD.4.2 Checks to the area

Prior to beginning work on systems containing FLAMMABLE REFRIGERANTS, safety checks are necessary to ensure that the risk of ignition is minimised. For repair to the REFRIGERATING SYSTEM.

DD.4.3 Work procedure

Work shall be undertaken under a controlled procedure so as to minimise the risk of a flammable gas or vapour being present while the work is being performed.

DD.4.4 General work area

All maintenance staff and others working in the local area shall be instructed on the nature of work being carried out. Work in confined spaces shall be avoided.

DD.4.5 Checking for presence of refrigerant

The area shall be checked with an appropriate refrigerant detector prior to and during work, to ensure the technician is aware of potentially toxic or flammable atmospheres. Ensure that the leak detection equipment being used is suitable for use with all applicable refrigerants, i. e. non-sparking, adequately sealed or intrinsically safe.

DD.4.6 Presence of fire extinguisher

If any hot work is to be conducted on the refrigerating equipment or any associated parts, appropriate fire extinguishing equipment shall be available to hand. Have a dry powder or CO₂ fire extinguisher adjacent to the charging area.

DD.4.7 No ignition sources

No person carrying out work in relation to a REFRIGERATING SYSTEM which involves exposing any pipe work shall use any sources of ignition in such a manner that it may lead to the risk of fire or explosion. All possible ignition sources, including cigarette smoking, should be kept sufficiently far away from the site of installation, repairing, removing and disposal, during which refrigerant can possibly be released to the surrounding space. Prior to work taking place, the area around the equipment is to be surveyed to make sure that there are no flammable hazards or ignition risks. "No Smoking" signs shall be displayed.

DD.4.8 Ventilated area

Ensure that the area is in the open or that it is adequately ventilated before breaking into the system or conducting any hot work. A degree of ventilation shall continue during the period that the work is carried out. The ventilation should safely disperse any released refrigerant and preferably expel it externally into the atmosphere.

DD.4.9 Checks to the refrigerating equipment

Where electrical components are being changed, they shall be fit for the purpose and to the correct specification. At all times the manufacturer's maintenance and service guidelines shall be followed. If in doubt, consult the manufacturer's technical department for assistance.

The following checks shall be applied to installations using FLAMMABLE REFRIGERANTS:

- the actual REFRIGERANT CHARGE is in accordance with the room size within which the refrigerant containing parts are installed;
- the ventilation machinery and outlets are operating adequately and are not obstructed;
- if an indirect refrigerating circuit is being used, the secondary circuit shall be checked for the presence of refrigerant;
- marking to the equipment continues to be visible and legible. Markings and signs that are illegible shall be corrected;
- refrigerating pipe or components are installed in a position where they are unlikely to be exposed

to any substance which may corrode refrigerant containing components, unless the components are constructed of materials which are inherently resistant to being corroded or are suitably protected against being so corroded.

DD.4.10 Checks to electrical devices

Repair and maintenance to electrical components shall include initial safety checks and component inspection procedures. If a fault exists that could compromise safety, then no electrical supply shall be connected to the circuit until it is satisfactorily dealt with. If the fault cannot be corrected immediately but it is necessary to continue operation, an adequate temporary solution shall be used. This shall be reported to the owner of the equipment so all parties are advised.

Initial safety checks shall include:

- that capacitors are discharged: this shall be done in a safe manner to avoid possibility of sparking;
- that no live electrical components and wiring are exposed while charging, recovering or purging the system;
- that there is continuity of earth bonding.

DD.5 Repairs to sealed components

DD.5.1 During repairs to sealed components, all electrical supplies shall be disconnected from the equipment being worked upon prior to any removal of sealed covers, etc. If it is absolutely necessary to have an electrical supply to equipment during servicing, then a permanently operating form of leak detection shall be located at the most critical point to warn of a potentially hazardous situation.

DD.5.2 Particular attention shall be paid to the following to ensure that by working on electrical components, the casing is not altered in such a way that the level of protection is affected. This shall include damage to cables, excessive number of connections, terminals not made to original specification, damage to seals, incorrect fitting of glands, etc.

Ensure that the apparatus is mounted securely.

Ensure that seals or sealing materials have not degraded to the point that they no longer serve the purpose of preventing the ingress of flammable atmospheres. Replacement parts shall be in accordance with the manufacturer's specifications.

DD.6 Repair to intrinsically safe components

Do not apply any permanent inductive or capacitance loads to the circuit without ensuring that this will not exceed the permissible voltage and current permitted for the equipment in use.

Intrinsically safe components are the only types that can be worked on while live in the presence of a flammable atmosphere. The test apparatus shall be at the correct rating.

Replace components only with parts specified by the manufacturer. Other parts may result in the ignition of refrigerant in the atmosphere from a leak.

NOTE The use of silicon sealant can inhibit the effectiveness of some types of leak detection equipment. Intrinsically safe components do not have to be isolated prior to working on them.

DD.7 Cabling

Check that cabling will not be subject to wear, corrosion, excessive pressure, vibration, sharp edges or any other adverse environmental effects. The check shall also take into account the effects of aging or continual vibration from sources such as compressors or fans.

DD.8 Detection of flammable refrigerants

Under no circumstances shall potential sources of ignition be used in the searching for or detection of refrigerant leaks. A halide torch (or any other detector using a naked flame) shall not be used.

The following leak detection methods are deemed acceptable for all refrigerant systems.

Electronic leak detectors may be used to detect refrigerant leaks but, in the case of FLAMMABLE REFRIGERANTS, the sensitivity may not be adequate, or may need re-calibration. (Detection equipment shall be calibrated in a refrigerant-free area.) Ensure that the detector is not a potential source of ignition and is suitable for the refrigerant used. Leak detection equipment shall be set at a percentage of the LFL of the refrigerant and shall be calibrated to the refrigerant employed, and the appropriate percentage of gas (25 % maximum) is confirmed.

Leak detection fluids are also suitable for use with most refrigerants but the use of detergents containing chlorine shall be avoided as the chlorine may react with the refrigerant and corrode the

copper pipe-work

NOTE Examples of leak detection fluids are

- bubble method,
- fluorescent method agents

If a leak is suspected, all naked flames shall be removed/extinguished.

If a leakage of refrigerant is found which requires brazing, all of the refrigerant shall be recovered from the system, or isolated (by means of shut off valves) in a part of the system remote from the leak.

DD.9 Removal and evacuation

When breaking into the refrigerant circuit to make repairs - or for any other purpose - conventional procedures shall be used. However, for flammable refrigerants it is important that best practice be followed, since flammability is a consideration. The following procedure shall be adhered to:

- a) safely remove refrigerant following local and national regulations;
- b) purge the circuit with inert gas;
- c) evacuate (optional for A2L);
- d) purge with inert gas (optional for A2L);
- e) open the circuit by cutting or brazing.

The refrigerant charge shall be recovered into the correct recovery cylinders if venting is not allowed by local and national codes. For appliances containing flammable refrigerants, the system shall be purged with oxygen-free nitrogen to render the appliance safe for flammable refrigerants. This process might need to be repeated several times.

Compressed air or oxygen shall not be used for purging refrigerant systems.

For appliances containing flammable refrigerants, refrigerants purging shall be achieved by breaking the vacuum in the system with oxygen-free nitrogen and continuing to fill until the working pressure is achieved, then venting to atmosphere, and finally pulling down to a vacuum (optional for A2L). This process shall be repeated until no refrigerant is within the system (optional for A2L). When the final oxygen-free nitrogen charge is used, the system shall be vented down to atmospheric pressure to enable work to take place.

Ensure that the outlet for the vacuum pump is not close to any potential ignition sources and that ventilation is available.

DD.10 Charging procedures

In addition to conventional charging procedures, the following requirements shall be followed.

- Ensure that contamination of different refrigerants does not occur when using charging equipment. Hoses or lines shall be as short as possible to minimise the amount of refrigerant contained in them.
- Cylinders shall be kept in an appropriate position according to the instructions.
- Ensure that the REFRIGERATING SYSTEM is earthed prior to charging the system with refrigerant.
- Label the system when charging is complete (if not already).
- Extreme care shall be taken not to overfill the REFRIGERATING SYSTEM.

Prior to recharging the system, it shall be pressure-tested with the appropriate purging gas. The system shall be leak-tested on completion of charging but prior to commissioning. A follow up leak test shall be carried out prior to leaving the site.

DD.11 Decommissioning

Before carrying out this procedure, it is essential that the technician is completely familiar with the equipment and all its detail. It is recommended good practice that all refrigerants are recovered safely. Prior to the task being carried out, an oil and refrigerant sample shall be taken in case analysis is required prior to re-use of recovered refrigerant. It is essential that electrical power is available before the task is commenced.

- a) Become familiar with the equipment and its operation.
- b) Isolate system electrically.
- c) Before attempting the procedure, ensure that:
 - mechanical handling equipment is available, if required, for handling refrigerant cylinders;
 - all personal protective equipment is available and being used correctly;
 - the recovery process is supervised at all times by a competent person;

- recovery equipment and cylinders conform to the appropriate standards.
- d) Pump down refrigerant system, if possible.
- e) If a vacuum is not possible, make a manifold so that refrigerant can be removed from various parts of the system.
- f) Make sure that cylinder is situated on the scales before recovery takes place.
- g) Start the recovery machine and operate in accordance with instructions.
- h) Do not overfill cylinders (no more than 80 % volume liquid charge).
- i) Do not exceed the maximum working pressure of the cylinder, even temporarily.
- j) When the cylinders have been filled correctly and the process completed, make sure that the cylinders and the equipment are removed from site promptly and all isolation valves on the equipment are closed off.
- k) Recovered refrigerant shall not be charged into another REFRIGERATING SYSTEM unless it has been cleaned and checked.

DD.12 Labelling

Equipment shall be labelled stating that it has been de-commissioned and emptied of refrigerant. The label shall be dated and signed. For appliances containing FLAMMABLE REFRIGERANTS, ensure that there are labels on the equipment stating the equipment contains FLAMMABLE REFRIGERANT.

DD.13 Recovery

When removing refrigerant from a system, either for servicing or decommissioning, it is recommended good practice that all refrigerants are removed safely.

When transferring refrigerant into cylinders, ensure that only appropriate refrigerant recovery cylinders are employed. Ensure that the correct number of cylinders for holding the total system charge is available. All

cylinders to be used are designated for the recovered refrigerant and labelled for that refrigerant (i. e. special cylinders for the recovery of refrigerant). Cylinders shall be complete with pressure-relief valve and associated shut-off valves in good working order. Empty recovery cylinders are evacuated and, if possible, cooled before recovery occurs.

The recovery equipment shall be in good working order with a set of instructions concerning the equipment that is at hand and shall be suitable for the recovery of all appropriate refrigerants including, when applicable, FLAMMABLE REFRIGERANTS. In addition, a set of calibrated weighing scales shall be available and in good working order. Hoses shall be complete with leak-free disconnect couplings and in good condition. Before using the recovery machine, check that it is in satisfactory working order, has been properly maintained and that any associated electrical components are sealed to prevent ignition in the event of a refrigerant release. Consult manufacturer if in doubt.

The recovered refrigerant shall be returned to the refrigerant supplier in the correct recovery cylinder, and the relevant waste transfer note arranged. Do not mix refrigerants in recovery units and especially not in cylinders.

If compressors or compressor oils are to be removed, ensure that they have been evacuated to an acceptable level to make certain that FLAMMABLE REFRIGERANT does not remain within the lubricant. The evacuation process shall be carried out prior to returning the compressor to the suppliers. Only electric heating to the compressor body shall be employed to accelerate this process. When oil is drained from a system, it shall be carried out safely.



pac_service@outlook.com